

**Ceiling unit**  
**Pure'line 90 cm**  
**White**

EAN 5414425116553

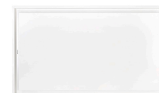

### Energy label

▪ Energy Efficiency class (EEIhood)	A++
▪ Annual Energy Consumption (kWh/year) (AEChood)	24,7
▪ Fluid Dynamic Efficiency class (FDEhood)	A
▪ Lighting Efficiency class (LEhood)	-
▪ Grease Filtering Efficiency class (GFEhood)	E

### Functions & features

▪ Control method	Push buttons + Remote control
▪ Number of speeds	3 + power
▪ Automatic Power revert (minutes)	6
▪ Motor	Integrated & Remote
▪ Sound absorber	Integrated
▪ Recirculation	Optional
▪ InTouch function	Standard
▪ Auto stop	▪
▪ Delayed switch off (minutes)	10/30
▪ Number of grease filters	2
▪ Grease filter	6830020
▪ Grease filter cleaning indication	▪
▪ Recirculation filter cleaning indication	▪

### Dimensions

▪ Product dimensions (WxDxH) (mm)	868 x 508 x 313
▪ Height incl. mounting clamps (without motorbox) (mm)	133
▪ Width flange (mm)	15
▪ Dimensions cut-out opening (WxD) (mm)	845 x 485
▪ Advised mounting height induction hobs (Hmin-Hmax) (mm)	600 - 1600
▪ Advised mounting height gas hobs (Hmin-Hmax) (mm)	650 - 1600
▪ Advised mounting height ceramic hobs (Hmin-Hmax) (mm)	600 - 1600
▪ Diameter outlet (mm)	150
▪ Position exhaust	Top, Right, Left, Front, Back

### Lighting

▪ Dimmable light	-
▪ Soft-ON/OFF	-
▪ External light connector	220-230V / max 300W / Not Dimmable

### Airflow and noise level

▪ Airflow (m <sup>3</sup> /h) measured according to EN 61591	
▪ Sound regulation according to EN 60704-2-13	
▪ Airflow speed 1 (m <sup>3</sup> /h) / Max Pressure speed 1 (Pa)	256 / 86

**Airflow and noise level**

---

▪ Airflow speed 2 (m <sup>3</sup> /h) / Max Pressure speed 2 (Pa)	417 / 253
▪ Airflow speed 3 (m <sup>3</sup> /h) / Max Pressure speed 3 (Pa)	549 / 382
▪ Airflow Powerspeed (m <sup>3</sup> /h) / Max Pressure Powerspeed (Pa)	624 / 382
▪ Sound pressure speed 1 (dB(A)) / Sound power speed 1 (dB(A))	24 / 35
▪ Sound pressure speed 2 (dB(A)) / Sound power speed 2 (dB(A))	35 / 47
▪ Sound pressure speed 3 (dB(A)) / Sound power speed 3 (dB(A))	42 / 55
▪ Sound pressure Powerspeed (dB(A)) / Sound Powerspeed (dB(A))	46 / 58

**Technical specifications**

---

▪ Maximum power	105
▪ Voltage (V)	220-230
▪ Frequency (Hz)	50
▪ Length power supply cord (m)	1,2
▪ Power consumption in stand-by-mode (Ps) (W)	0.29
▪ Net weight (kg)	21

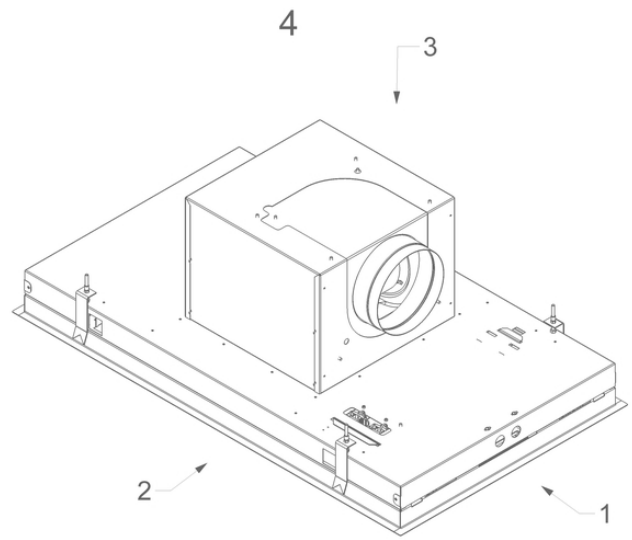
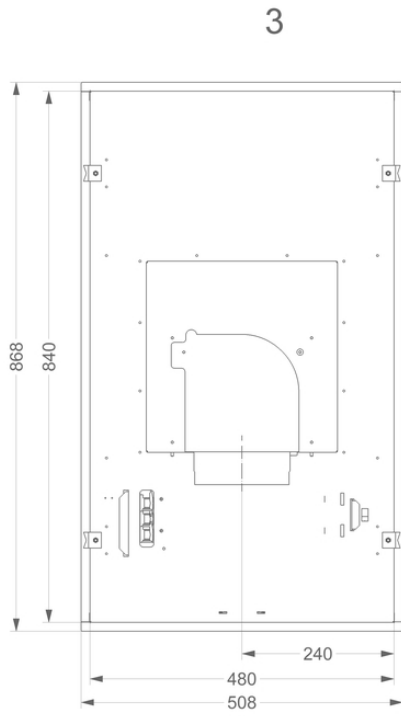
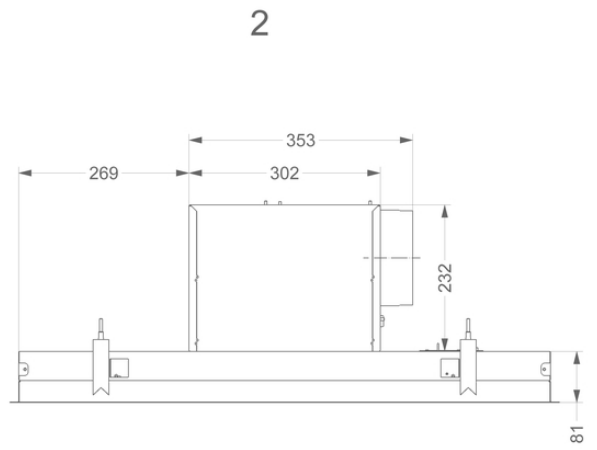
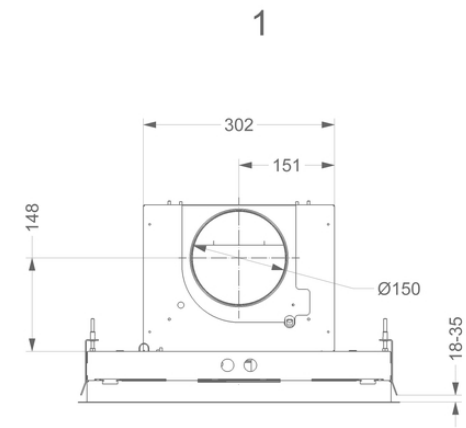

**Installation accessories**

---

**Extension cable**

▪ 7000094

Extension cable 5 m

**Accessories**

---

**Recirculation box**

841400

recirculation box with monoblock white (270x500mm)



842400

recirculation box with monoblock black (270x500mm)



843400

recirculation box with monoblock grey (270x500mm)

**Adapter for limited installation height**

6830052

Adapter for limited installation height 17,3 cm

**Control kit**

990030

Control kit for external lighting or valve

## Efficiency Curve

